

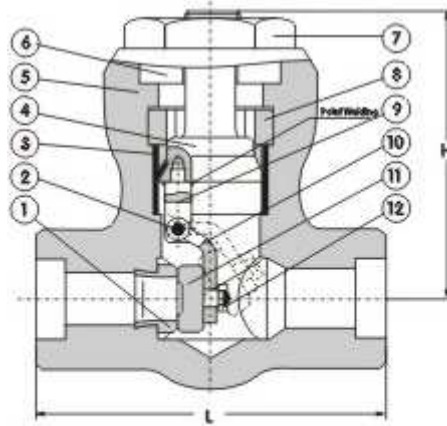

**PRESSURE-SEAL SWING CHECK VALVE 900LB~2500LB**



**Eg.FIG.PS25C4Y**

Features:

**Pressure-seal Swing Check Valve 900Lb~2500Lb**

**Standard Material Specifications**

NO.	Part Name	CS to ASTM	AS to ASTM	SS to ASTM	
		Type A105	Type F22	Type F304(L)	Type F316(L)
1	Seat Ring	A276 410	A276 304	A276 304(L)	A276 316(L)
2	Pin	A276 420		A182 F304	A182 F316
3	Pressure Ring	A276 304L			A276 316(L)
4	Pressure Seat	A105	A182 F304	A182 F304(L)	A182 F316(L)
5	Body	A105	A182 F22	A182 F304(L)	A182 F316(L)
6	Bonnet	A105	A182 F22	A182 F304 L	A182 F316(L)
7	Bolt	A193 B7	A193 B16	A193 B8	A193 B8M
8	Quarter Ring	A276 420	A182 F304		A182 F316
9	Pontlevis	A105	A182 F22	A182 F304 L	A182 F316(L)
10	Hinge	A105	A182 F22	A182 F304 L	A182 F316(L)
11	Disc	A276 420	F304	A182 F304(L)	F316(L)
12	Nut	A194 2H	A194 4	A194 8	A194 8M
Suitable Medium		W.O.G.etc	W.O.G.etc	HNO <sub>3</sub> ,CH <sub>3</sub> OOH etc	



**Note:** Other materials are available upon request.

**Dimensions (mm) and Weights (Kg)**

NPS		1/2"	3/4"	1"	1-1/4"	1-1/2"	2"
L	900~1500Lb	140	140	140	178	178	216
	2500Lb	186	186	186	232	232	279
H		117	117	117	152	152	195
Weights	900~1500Lb	8.2	7.8	7.7	19.8	19.2	21.3